

[®] ***HYPERPRO***
Suspension Technology

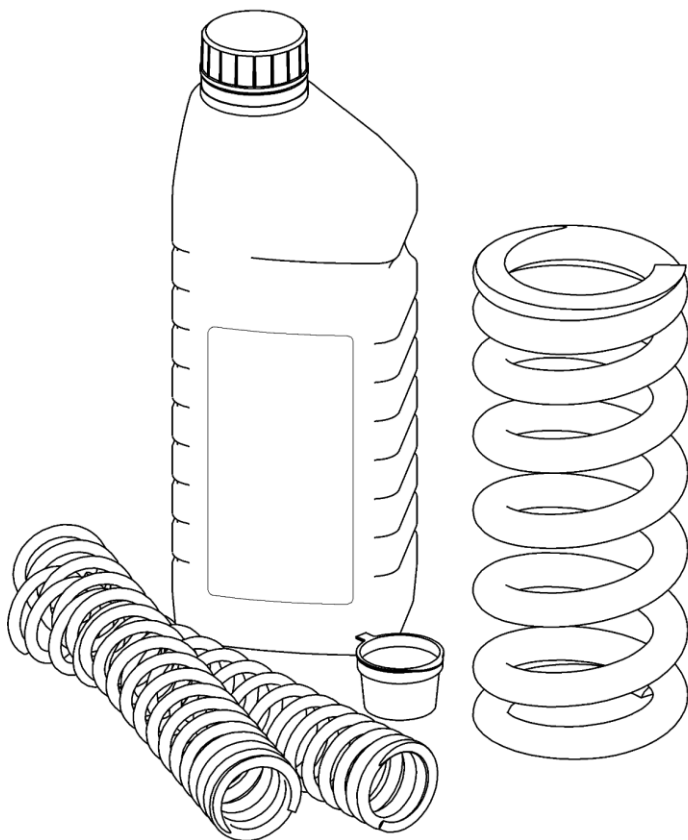

Spring manual

V3.4.1 ENGLISH

HYPERPRO TOOLS, used in this manual:

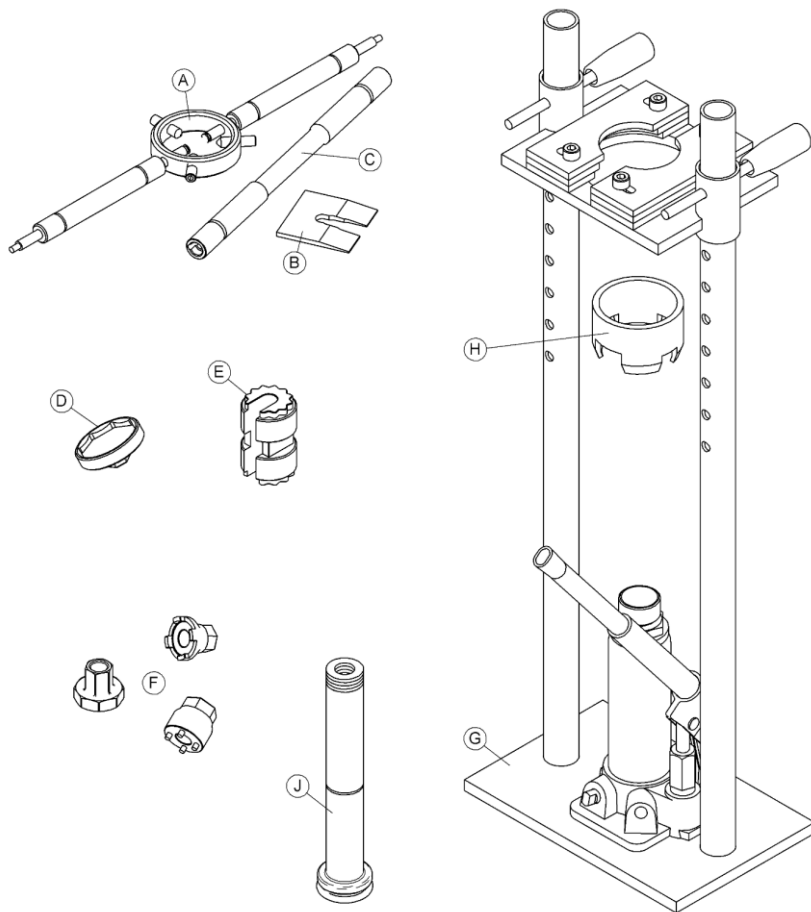

Tool	Description	Part no.
A, B, C	Cartridge fork spring removal tool kit	HP-T01
D	Big Piston Fork end cap socket 45mm	HP-T102
E	Big Piston Fork cartridge socket wrench	HP-T101
F	Fork cap and cartridge tools (required for some models)	see label
G	Shock spring removal tool	HP-T02
H	Hydraulic preload adapter for spring removal tool	HP-T26
J	SFF BP fork disassembly	HP-T90

INDEX

		<i>Page</i>
<i>Front Fork Spring change</i>		
F1	Basic fork	4
F2	Cartridge fork	7
F3	Big Piston fork	11
F4	SFF BP fork (2021>)	14
F5	Other fork types	18
F6	Fork maintenance	18
<i>Rear Shock unit, removal and installation</i>		
M1	Mono shock (& Telelever front)	19
M2	Twin shock	19
M3	Link system	20
<i>Shock Spring change</i>		
R1	Basic shock	21
R2	Shock with hydraulic preload adjuster	24
R3	Pull shock	26
R4	Shock maintenance	27
<i>Setup</i>		
S1	Things to check first	28
S2	Static Sag measurement and adjustment	29
S3	Damping setup	31
S4	Handling troubleshooting chart	35
<i>Setting Label</i>		36

Safety remarks – important safety information is highlighted by the following notations:

- **WARNING!** – Failure to follow warning could result in severe or fatal injury.
- **NOTE:** - Indicates information that is of importance with regard to procedure.

WARNING! – Please study this owner's manual and make sure that you fully understand the mounting instructions. If you have any questions regarding proper installation, contact a Hyperpro dealer.

F1: BASIC FORK

- 1 Measure the distance from the top of the **tubes** to the fork clamp (1). Loosen the upper fork clamp bolts (5).

Loosen the fork caps (4) about 0.5 turn.

If this is not possible in the normal position, move the forks down in the clamps (wheel and fender have to be removed first), clamp the tubes in the bottom clamp (6) at about 30 mm distance above and loosen the fork caps (4).

Tip: Use a piece of paper to help protect the caps from damaging.

Removing the fork first and unscrewing the caps later is difficult, it is virtually impossible to hold the fork tube. Always use the fork clamp to hold the fork; never place the fork tube in a vice as this causes damage to the tubes. It may be possible to hold the fork by hand when a compressed air wrench is used.

- 2 Place the bike stable with the front wheel off the ground. Remove the front fork from the bike. View the motorcycle's service manual for details.
- 3 Remove the fork caps (4) from the fork.

WARNING! The caps are under tension from the preload on the spring, be careful when removing!

- 4 Remove the internal parts from the fork: preload spacer (7), ring(s) and spring. Note where and how the parts fit, sometimes there is a tapered end on one side of the spring.

Pour the old oil into a tank. Hold the fork upside down and compress and decompress the fork to pump all the oil out of the fork (± 10 to 20 times, until there is no damping felt)

Old oil is harmful for the environment, dispose of it properly.

- 5 Inspect the parts for their condition. Broken parts and/ or leaking seals should be replaced. If an oil seal is replaced, be sure to also check the inner tube for damage.

Clean all the parts before reassembly.

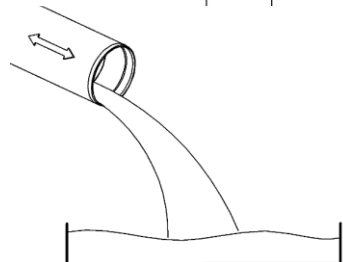
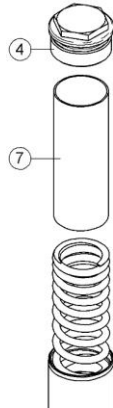
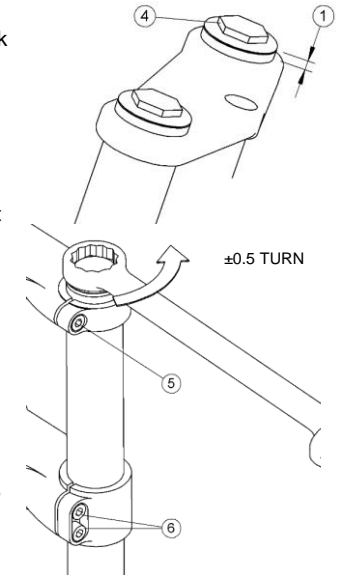

- 6 Fully compress the fork and fill it with HYPERPRO fork oil of the right viscosity (see label: **HYPERPRO OIL**), just below the required level (see label: **OIL LEVEL**).

Pump all the air out of the fork by compressing and decompressing the fork (± 10 to 20 times)

- 7 To measure the oil level (air chamber): fully compress the fork and **do not fit the spring, spacer and other loose parts**. Make sure the fork is compressed in the **hydraulic lock**; when compressing becomes heavier, push further until steel to steel contact is felt.

The oil level is the distance between the top of the tube and the oil inside. Hold the fork straight up. Use a tape measure; slide it in until it just lightly touches the oil in the fork, hold it against the upper edge of the tube and read.

Add or remove oil until the required level is reached (see label: **OIL LEVEL**). Make sure there is no air in the fork (see step 6).

- 8 Mount the HYPERPRO spring in the fork. Check the label for the mounting direction, usually the progressive side is mounted up* (see picture). Sometimes there is a sticker marking which side up; remove the sticker before use.

Fit the ring(s) and the preload spacer if present. The mounting order of the parts is the same as original*. **(* unless there is a remark on the label.**

- 9 Mount the fork caps (4) in the fork. Hold the tube, compress the spring using the fork cap and screw it in the tube. Make sure the cap is screwed a few turns in before releasing the pressure as the spring preload pushes the cap out, it could jump out when released.

For fork caps with rebound adjustment rod:

Make sure the adjustment rod fits correctly in the cartridge. The adjustment rod should fit in the middle of the cartridge; it slides onto an adjustment mechanism inside the fork and usually fits one way because of a flat side on the adjustment rod. The rod slides smoothly over the adjuster inside, don't push on the cap as this damages the adjustment rod. If there is a gap between the preload bush or spring and the cap, the adjustment rod is not fitted in the cartridge correctly, take it out and fit it again until it is placed correctly.

When the fork cap is placed correctly, the bottom of the cap **sits on the preload spacer or spring**, with (almost) no room in between. Push on the fork cap, **directly compressing the spring**, and screw it in the tube. Make sure the cap is screwed a few turns in before releasing the pressure as the spring preload pushes the cap out, it could jump out when released.

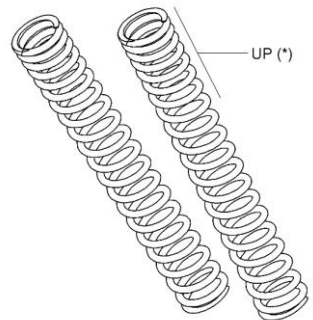
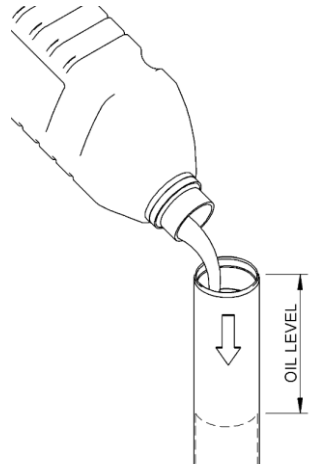

- 10 If available, set the spring preload (3) as specified (see label: **SPRING PRELOAD**). Preload is specified by the amount of rings that are visible on the adjuster. Less rings showing indicates more preload (unless the fork has reversed preload, check the label for a remark). The preload can be adjusted to set the static sag, turn the adjuster clockwise for more preload (see Setup chapter S2).

If available, set the rebound damping (2) as specified (see label: **REBOUND**).

- 11 HYPERPRO fork grease reduces the friction of the front fork. Carefully prise off the dust seals from the outer tube of the fork with a small flat screwdriver. Put the grease on the inner tube of the fork (11). Move the fork in and out. Repeat this.

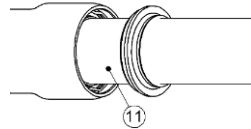

Put some grease on the dust seals to make them slide in more easily. Refit the dust seals and remove the excess grease.

- 12 Reassemble the bike, view the motorcycle's service manual for details. Fit the fork at the distance as measured at step 1; **unless there is a remark on the label.**

Make sure everything is tightened to the correct torque setting.

- 13 With the bike back on its wheels, loosen the pinch bolt(s) of the front axle (13).

Push the front fork a few times as deep as possible to let the fork settle itself in the position with the least friction.

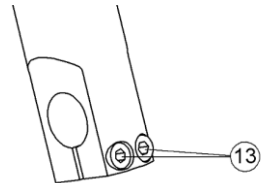

Tighten the front axle pinch bolt(s) (13).

F2: CARTRIDGE FORK

- 1 Measure the distance from the top of the **tubes** to the fork clamp (1). Loosen the upper fork clamp bolts (5).

Loosen the fork caps (4) about 0.5 turn.

If this is not possible in the normal position, move the forks down in the clamps (wheel and fender have to be removed first), clamp the tubes in the bottom clamp (6) at about 30 mm distance above and loosen the fork caps (4).

Tip: Use a piece of paper to help protect the caps from damaging.

Removing the fork first and unscrewing the caps later is difficult, it is virtually impossible to hold the fork tube. Always use the fork clamp to hold the fork; never place the fork tube in a vice as this causes damage to the tubes. It may be possible to hold the fork by hand when a compressed air wrench is used.

- 2 Place the bike stable with the front wheel off the ground. Remove the front fork from the bike. View the motorcycle's service manual for details.
- 3 If available, turn the damping adjusters on top of the fork (2) clockwise until the damping is fully closed; this will make it easier to correctly assemble the fork later. The position of the adjusters at the bottom of the fork (12) is not important.

Remove the fork caps (4) from the fork. Move the tube down, exposing the preload spacer (7).

- 4 Place tool (A) through the holes in the preload spacer (7). If there are no holes, clamp the spacers using the 3 bolts in tool (A), not too tight as this can cause damage. Press the spacer and spring down using tool (A). Let a second person pull the damper rod out with the fork cap (4) and place plate (B) between the nut (8) and the spacer (7).

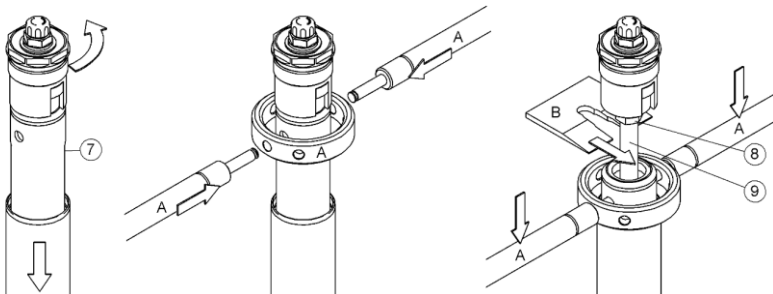
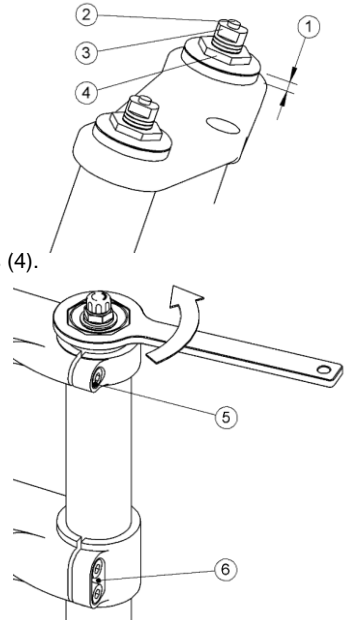

If the front fork has reversed preload adjustment (see label for a remark) the preload has to be set to the minimum (1 ring showing) before this can be done.

- 5 Hold the nut (8) with a spanner and remove the fork cap (4) by turning the preload adjuster (3).

Remove the rebound adjustment pin (10); sometimes it's attached to the fork cap. Note how the adjustment rod fits the fork.

- 6 Screw tool (C) on the damper rod. Press down on tool (A), let a second person pull the damper rod up and remove plate (B).

- 7 Remove tool (A), then remove the internal parts from the fork: preload spacer (7), ring(s) and spring. Note where and how the parts fit, sometimes there is a tapered end on one side of the spring.

- 8 Pour the old oil into a tank. Hold the fork upright and pump the fork: move the damper rod and inner tube up and down slowly a few times to pump all the oil out of the damping cartridge. Hold the fork upside down and pour the oil out of the fork. Then pump the fork again. Repeat this procedure a few times to remove all the oil from the fork (± 5 times, until there is no damping felt).

Old oil is harmful for the environment, dispose of it properly.

- 9 Inspect the parts for their condition. Broken parts and/or leaking seals should be replaced. If an oil seal is replaced, be sure to also check the inner tube for damage.

Clean all the parts before reassembly.

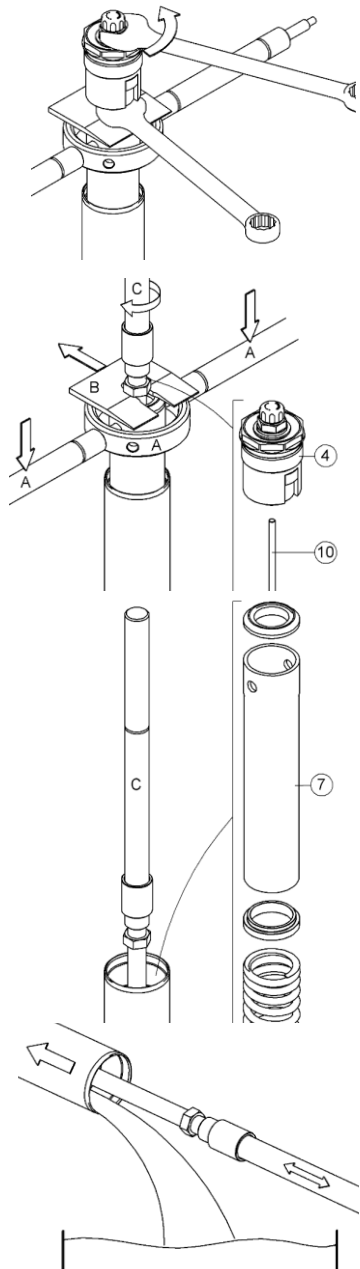

- 10 Fully compress the fork and fill it with HYPERPRO fork oil of the right viscosity (see label: **HYPERPRO OIL**), just below the required level (see label: **OIL LEVEL**).

Pump out all the air of the fork by slowly compressing and decompressing the fork and damping rod (± 10 to 20 times)

- 11 To measure the oil level (air chamber): fully compress the fork and **do not fit the spring, spacer and other loose parts**. Make sure the fork is compressed in the **hydraulic lock**; when compressing becomes heavier, push further until steel to steel contact is felt.

The oil level is the distance between the top of the tube and the oil inside. Hold the fork straight up. Use a tape measure; slide it in until it just lightly touches the oil in the fork, hold it against the upper edge of the tube and read.

Add or remove oil until the required level is reached (see label: **OIL LEVEL**). Make sure there is no air in the fork (see step 10).

- 12 Mount the HYPERPRO spring in the fork. Check the label for the mounting direction, usually the progressive side is mounted up* (see picture). Sometimes there is a sticker marking which side up; remove the sticker before use.

Fit the ring(s) and the preload spacer if present. The mounting order of the parts is the same as original*.

(*) unless there is a remark on the label.

- 13 Place tool (A) on the preload spacer (7). Compress the spacer and spring. Let a second person pull out the damper rod and place plate (B) between the nut (8) and the preload spacer (7).
- 14 Screw the nut (8) down a bit. Remove tool C. Fit the rebound adjustment pin (10) in the damper rod (9). Screw the fork cap (4) onto the damper rod until it stops, **do not overtighten** as this upsets the adjustment mechanism. Hold the cap (4) and tighten the nut (8) against the cap.
- 15 Press down on tool (A). Let a second person remove plate (B). Slowly decompress the spring, making sure everything correctly finds its place.
- 16 Pull the tube up and mount the fork caps (4) in the fork.

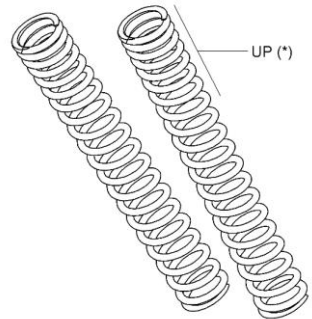
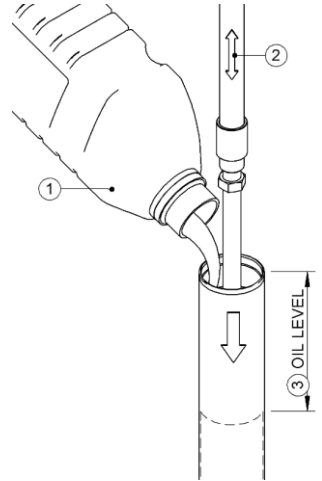

- 17 If available, set the spring preload (3) as specified (see label: **SPRING PRELOAD**). Preload is specified by the amount of rings that are visible on the adjuster. Less rings showing indicates more preload (unless the fork has reversed preload, check the label for a remark). The preload can be adjusted to set the static sag, turn the adjuster clockwise for more preload (see Setup chapter S2).

Set the available damping adjusters as specified (see label: **REBOUND & COMPRESSION**). The rebound screw (2) is located on the top of the fork. The compression adjustment screw is usually located on the bottom of the fork (12).

Clicks or turns are counted from the maximum setting out: First turn the screw in (clockwise) to the maximum setting. Then turn the screw out (counter clockwise) with the number of clicks or turns specified on the label.

- 18 HYPERPRO fork grease reduces the friction of the front fork. Carefully prise off the dust seals from the outer tube of the fork with a small flat screwdriver. Put the grease on the inner tube of the fork (11). Move the fork in and out. Repeat this.

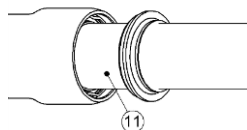

Put some grease on the dust seals to make them slide in more easily. Refit the dust seals and remove the excess grease.

- 19 Reassemble the bike, view the motorcycle's service manual for details. Fit the fork at the distance as measured at step 1; **unless there is a remark on the label**

Make sure everything is tightened to the correct torque setting.

- 20 With the bike back on its wheels, loosen the pinch bolt(s) of the front axle (13).

Push the front fork a few times as deep as possible to let the fork settle itself in the position with the least friction.

Tighten the front axle pinch bolt(s) (13).

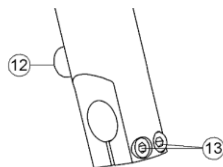

F3: BIG PISTON FORK

- 1 Measure the distance from the top of the **tubes** to the fork clamp (1). Loosen the upper fork clamp bolts (5).

Loosen the fork caps (4) about 0.5 turn (requires special tool (D)).

Tip: Use a piece of paper to help protect the caps from damaging.

Removing the fork first and unscrewing the caps later is difficult, it is virtually impossible to hold the fork tube. Always use a fork clamp to hold the fork; never place the fork tube in a vice as this causes damage to the tubes. It may be possible to hold the fork by hand when a compressed air wrench is used.

- 2 Place the bike stable with the front wheel off the ground. Remove the front fork from the bike. View the motorcycle's service manual for details.
- 3 Remove the fork caps (4) from the tube. Move the tube down, exposing the damper rod (9).

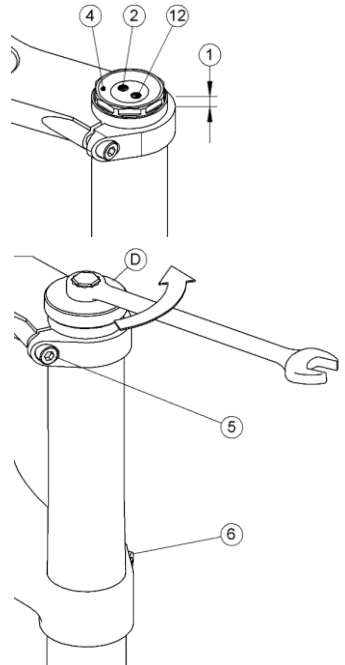

- 4 The end of the cartridge (14) can be seen inside the tube. Clamp the foot of the fork in a bench vice with soft jaws. Place tool (E) over the damper rod and inside the cartridge socket, make sure you are using the correct side of the tool. Use a spanner on tool (E) and turn counter clockwise to loosen the cartridge. Remove the cartridge from the fork.

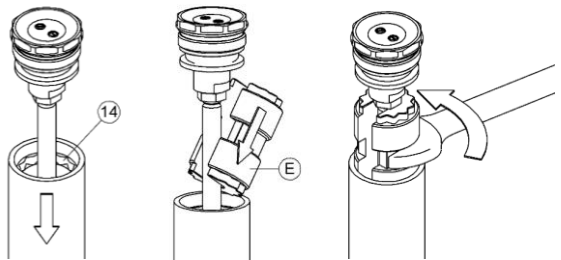

- 5 Pour the old oil into a tank. Pump the fork: move the tube up and down slowly a few times to pump all the oil out of the fork. Hold the fork upside down and pour the oil out of the fork. Then pump the fork again. Repeat this procedure a few times to remove all the oil from the fork (± 5 times, until there is no damping felt).

Old oil is harmful for the environment, dispose of it properly.

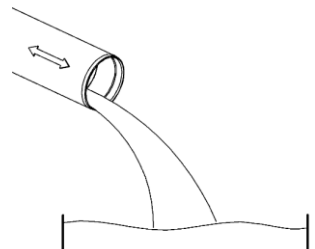

- 6 Remove the internal parts from the fork: spring platform, spring and preload spacer. Note where and how the parts fit.

Inspect the parts for their condition.

Broken parts and/ or leaking seals should be replaced. If an oil seal is replaced, be sure to also check the inner tube for damage.

Clean all the parts before reassembly.

- 7 Fully compress the fork and fill it with HYPERPRO fork oil of the right viscosity (see label: **HYPERPRO OIL**), just below the required level (see label: **OIL LEVEL**).

Pump out all the air of the fork by slowly compressing and decompressing the fork and damping rod (± 10 to 20 times)

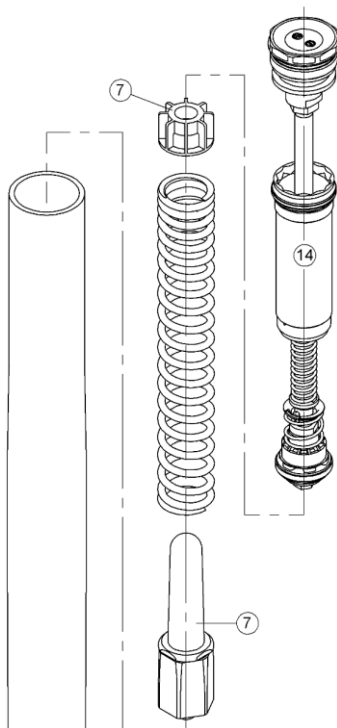

- 8 To measure the oil level (air chamber): fully compress the fork. Make sure the fork is compressed in the **hydraulic lock**; when compressing becomes heavier, push further until steel to steel contact is felt.

Oil level is usually measured without spring and other internal parts (**unless there is a remark on the label**).

The oil level is the distance between the top of the tube and the oil inside. Hold the fork straight up. Use a tape measure; slide it in until it just lightly touches the oil in the fork, hold it against the upper edge of the tube and read.

Add or remove oil until the required level is reached (see label: **OIL LEVEL**). Make sure there is no air in the fork (see step 7).

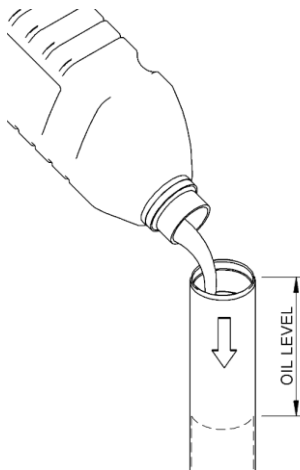

- 9 Mount the HYPERPRO spring in the fork.
Check the label for the mounting direction, usually the progressive side is mounted up* (see picture). Sometimes there is a sticker marking which side up; remove the sticker before use.

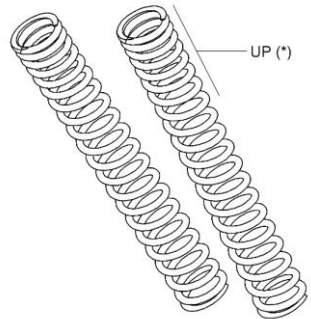

Fit the ring(s) and the preload spacer if present. The mounting order of the parts is the same as original* (*** unless there is a remark on the label**).

- 10 Place the cartridge in the tube and push down slowly. Clamp the foot of the fork in a bench vice with soft jaws. Place tool (E) over the damper rod and inside the cartridge socket, make sure you are using the correct side of the tool. Use a spanner on tool (E) and turn clockwise to tighten the cartridge.
- 11 Pull the tube up and mount the fork cap (4) in the fork.
- 12 Set the spring preload (3) as specified (see label: **SPRING PRELOAD**). It is located at the bottom of the fork. The preload can be adjusted to set the static sag, turn the adjuster clockwise for more preload (see Setup chapter S2).

Set the damping adjusters (2) & (12) as specified (see label: **REBOUND & COMPRESSION**). They are located on the top of the fork. Clicks or turns are counted from the maximum setting out: First turn the screw in (clockwise) to the maximum setting. Then turn the screw out (counter clockwise) with the number of clicks or turns specified on the label.

- 13 HYPERPRO fork grease reduces the friction of the front fork. Carefully prise off the dust seals from the outer tube of the fork with a small flat screwdriver. Put the grease on the inner tube of the fork (11). Move the fork in and out. Repeat this.

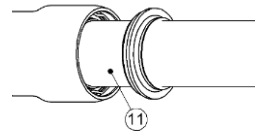

Put some grease on the dust seals to make them slide in more easily. Refit the dust seals and remove the excess grease.

- 14 Reassemble the bike, view the motorcycle's service manual for details. Fit the fork at the distance as measured at step 1 (**unless there is a remark on the label**).

Make sure everything is tightened to the correct torque setting.

- 15 With the bike back on its wheels, loosen the pinch bolt(s) of the front axle (13).

Push the front fork a few times as deep as possible to let the fork settle itself in the position with the least friction.

Tighten the front axle pinch bolt(s) (13).

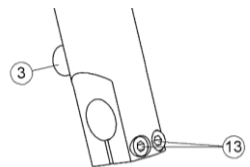

F4: SFF-BP FORK (2021>)

- 1 Measure the distance from the top of the **tubes** to the fork clamp (1). Loosen the upper fork clamp bolts (5).

Loosen the fork caps (4) about 0.5 turn (requires special tool (D)).

Tip: Use a piece of paper to help protect the caps from damaging.

Removing the fork first and unscrewing the caps later is difficult, it is virtually impossible to hold the fork tube. Always use a fork clamp to hold the fork; never place the fork tube in a vice as this causes damage to the tubes. It may be possible to hold the fork by hand when a compressed air wrench is used.

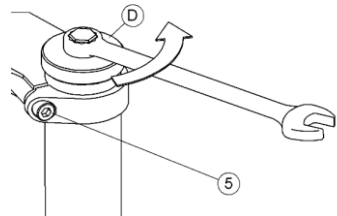
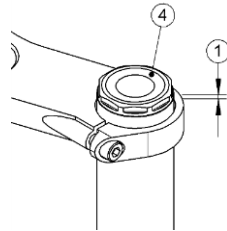

- 2 Place the bike stable with the front wheel off the ground. Remove the front fork from the bike. View the motorcycle's service manual for details.

- 3 Remove the fork caps (4) from the tube. Move the tube down, exposing the piston rod (9). Clip ring (15) can be seen inside the inner tube.

- 4 Clamp the foot of the fork in a bench vice with soft jaws. Push the fork cap to compress the fork spring, push down the seat ring (16) and remove the clip ring (15).

- 5 Remove the fork rod assembly by pulling it out.

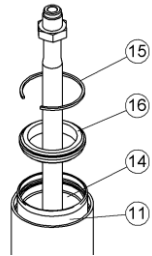
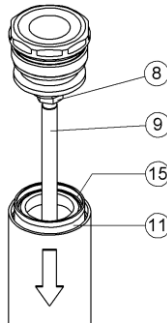

If the rod assembly will not slide out easily, it is necessary to pump it out:

Look inside the fork tube:

- no holes -> proceed to **5a**
- 4 holes -> proceed to **5b**



5a



5b

- 5a Loosen the lock nut (8) and remove the fork cap (4). Lift the outer tube to ± 150 mm stroke and pump the outer tube **up** quickly repeatedly, this creates internal pressure and pushes the end cap (14) of the fork rod assembly out of the fork tube.

Remove the fork rod assembly and proceed to step 6.

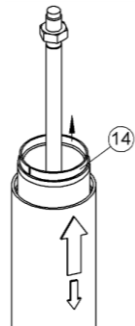

- 5b** Make sure the oil is on the same level as the top of the holes. Use Hyperpro tool J (part nr. HP-T90) to block the holes: Loosen the lock nut (8) and remove the fork cap (4). Do not remove the preload adjuster pin. Install tool J as shown, use as much washers as possible then mount tool C on top with the correct thread size.

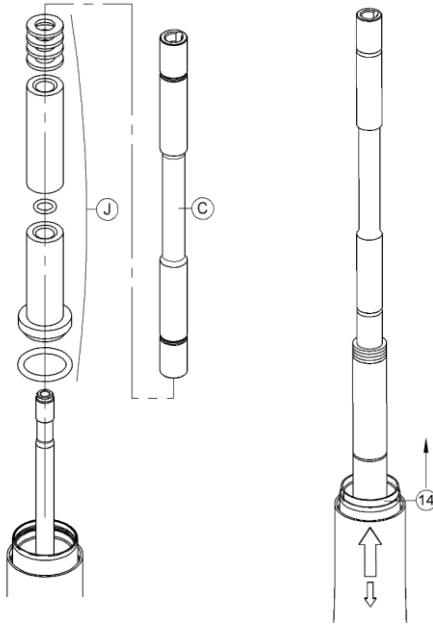

Lift the outer tube to ± 150 mm stroke and pump the outer tube **up** quickly repeatedly, this creates internal pressure and pushes the end cap (14) of the fork rod assembly out of the fork tube. It may be necessary to add more oil during this procedure.

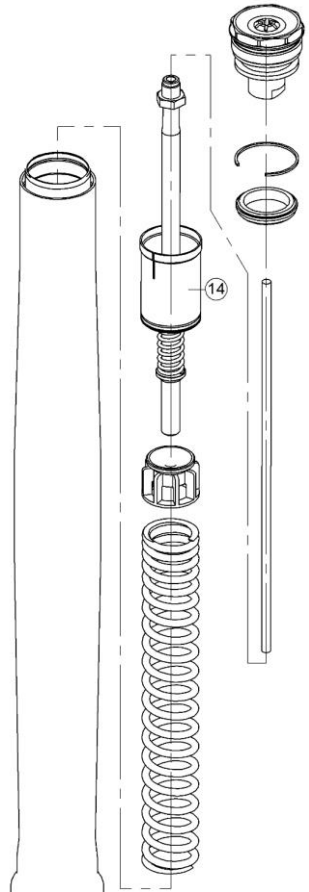

*SFF BP – spring side with
preload adjustment*

Remove the fork rod assembly and proceed to step **6**.

- 6** Pour the old oil into a tank. Pump the fork: move the tube up and down slowly a few times to pump all the oil out of the fork. Hold the fork upside down and pour the oil out of the fork. Then pump the fork again. Repeat this procedure a few times to remove all the oil from the fork (± 5 times, until there is no damping felt).

Old oil is harmful for the environment, dispose of it properly.

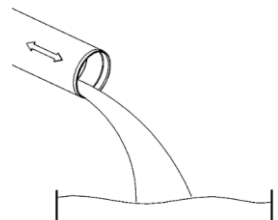

- 7 Remove the internal parts from the fork: spring platform, spring and preload spacer. Note where and how the parts fit.

Inspect the parts for their condition.

Broken parts and/ or leaking seals should be replaced. If an oil seal is replaced, be sure to also check the inner tube for damage.

Clean all the parts before reassembly.

If present: install a new O-ring (17) on the rod assembly (14).

- 8 Fully compress the fork and fill it with HYPERPRO fork oil of the right viscosity (see label: **HYPERPRO OIL**), just below the required level (see label: **OIL LEVEL**).

Pump out all the air of the fork by slowly compressing and decompressing the fork and damping rod (± 10 to 20 times)

- 9 To measure the oil level (air chamber): fully compress the fork. Make sure the fork is compressed in the **hydraulic lock**; when compressing becomes heavier, push further until steel to steel contact is felt.

Oil level is usually measured without spring and other internal parts (**unless there is a remark on the label**).

The oil level is the distance between the top of the tube and the oil inside. Hold the fork straight up. Use a tape measure; slide it in until it just lightly touches the oil in the fork, hold it against the upper edge of the tube and read.

Add or remove oil until the required level is reached (see label: **OIL LEVEL**). Make sure there is no air in the fork (see step 7).

- 10 Mount the HYPERPRO spring in the fork. Check the label for the mounting direction, usually the progressive side is mounted up* (see picture). Sometimes there is a sticker marking which side up; remove the sticker before use.

Fit the ring(s) and the preload spacer (7) if present. The mounting order of the parts is the same as original* (*** unless there is a remark on the label**).

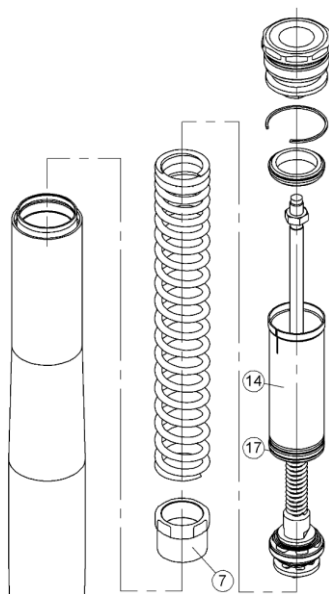

SFF BP – damping side

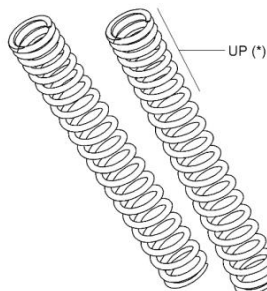
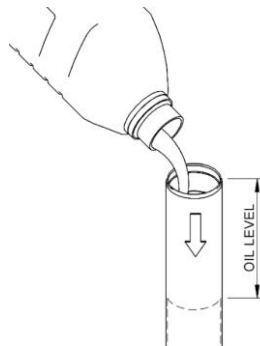

- 11 Clamp the foot of the fork in a bench vice with soft jaws. Mount the fork cap (4) to the piston rod (9) and tighten the lock nut (8). Place the fork rod assembly in the tube and push down slowly until the clip ring (15) can be installed on the seat ring (16) in the groove in the fork tube.

If it is difficult to press the rod assembly:
 - Use tool J (without O-rings, see picture) or a pipe to push inside the rod assembly (14).
 - Make sure the adjuster pin is not installed yet.

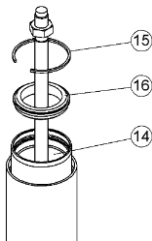
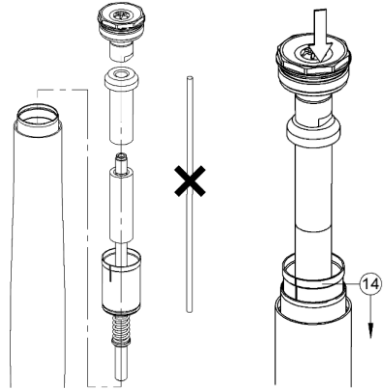

Remove the tools. Install the seat ring (16) and the clip ring (15). Install the adjuster pin and mount the fork cap (4) to the rod.

- 12 Pull the tube up and mount the fork cap (4) in the fork.
- 13 HYPERPRO fork grease reduces the friction of the front fork. Carefully prise off the dust seals from the outer tube of the fork with a small flat screwdriver. Put the grease on the inner tube of the fork (11). Move the fork in and out. Repeat this.

Put some grease on the dust seals to make them slide in more easily. Refit the dust seals and remove the excess grease.

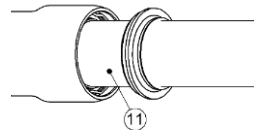

- 14 Reassemble the bike, view the motorcycle's service manual for details. Fit the fork at the distance as measured at step 1 (**unless there is a remark on the label**).

Make sure everything is tightened to the correct torque setting.

- 15 With the bike back on its wheels, loosen the pinch bolt(s) of the front axle (13).

Push the front fork a few times as deep as possible to let the fork settle itself in the position with the least friction.

Tighten the front axle pinch bolt(s) (13).

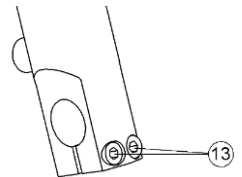

F5: OTHER FORK TYPES

Unfortunately we cannot cover all different fork types. For these and other fork types, please refer to your vehicle's or fork manufacturer's service manual:

- **Separate Function Forks** have different fork legs left and right. Some have compression damping in one leg and rebound in the other. Some have only one leg with a damping system. Some have only one fork leg with spring. In general, the instructions in the previous chapters should enable you to change the fork springs, but sometimes special tools are required. Check the label for remarks.
- **Closed Cartridge (MX) Forks** contain a complete pressurized damping unit, very similar to a shock absorber. The spring is fitted underneath or around the damping unit. The fork legs do contain oil for lubrication purposes. Open the fork cap and drain the oil from the top. Screw the fork cap back in and clamp the bottom of the fork in a vice. Loosen the bolt that holds the internal damper from the bottom and pull it out, exposing the damper rod. Use tool (B) to keep the lock nut outside of the fork and remove the bolt. Remove tool (B). Now when you open the fork cap again, it can be removed along with the damper unit and spring.

F6. FORK MAINTENANCE

For proper maintenance of OEM forks, please refer to the manufacturer's service manual.

In general, inspect the fork regularly for damage and leakage. Wash the fork with a mild detergent. Be careful with compressed air and avoid using aggressive cleaners. Protect your fork with WD40 or similar.

- Every 10000km or 1 year clean and apply fork grease to the inner tube.
- Every 20000km or 2 years change the fork oil. Use only HYPERPRO oil to be sure of the correct viscosity and quality.

HYPERPRO progressive fork springs come with a lifetime warranty against breaking.

REAR SHOCK MOUNTING INSTRUCTIONS

NOTE: We strongly advise to follow your vehicle's workshop manual for the correct mounting procedure.

- 1 Place the bike firm and stable with the rear wheel free from the ground. Do not use a bike stand that supports the swing arm.
- 2 Remove cases, seats and bodywork if necessary to reach the mounting points of the shock absorber.
- 3 If the shock has a remote reservoir and/ or hydraulic preload with a remote adjuster, they have to be removed from the bike along with the shock. Remove the bolt(s) or clamp(s) of the remote parts, so they are loose and can be removed.

WARNING! - The hoses must not be detached from the shock, system can be pressurized!

M1. MONO SHOCK (& TELELEVER FRONT)

- 4 Remove the nuts from the shock absorber mounting bolts (1 & 2).
- 5 Support or lift the rear wheel to take out the shock bolts and remove the shock from the bike.
- 6 Exchange the original spring for the HYPERPRO spring (see chapters R1-R3)
- 7 Place the shock in the motorcycle. Place the top bolt (1). Lift the rear wheel up to place the bottom bolt (2). Tighten the nuts to the correct torque settings. If present, mount the remote reservoir and/ or remote preload adjuster to the bike.

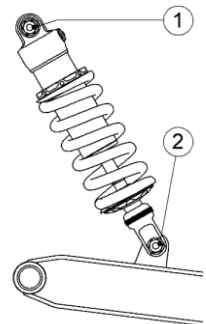

M1 - mono shock

M2. TWIN SHOCK

- 4 Remove the nuts from the shock absorber mounts (1 & 2).
- 5 Support or lift the rear wheel to take out the shock bolt(s) and remove the shocks from the bike.
- 6 Exchange the original springs for the HYPERPRO springs (see chapters R1-R3)
- 7 Place the shocks in the motorcycle. Place the top bolt or nut (1). Lift the rear wheel up to place the bottom bolt (2). Tighten the bolts and/ or nuts.

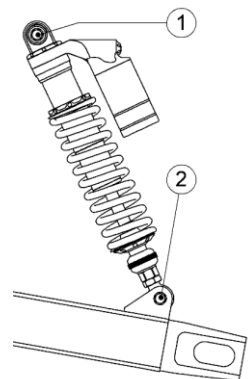

M2 - twin shock

M3. LINK SYSTEM

The link system can be found underneath the swing arm. Sometimes it is necessary to remove parts of the exhaust or bodywork for better access.

NOTE: make sure all link system parts can be mounted in the correct position and direction. Check for markings (e.g.: arrows) or make your own, take pictures and check your vehicle's service manual. Incorrect assembly influences the handling and may lead to dangerous situations!

Check the condition of the rear suspension parts. Clean and re-grease where necessary. Check all bearings and seals for damage and excessive play, replace them if necessary.

M3.1 LINK SYSTEM – STRAIGHT LINK PLATES

- 4 Remove nuts (3) and (4). Support or lift the rear wheel to remove the bolts and link plates (5).
- 5 Remove the nuts from the shock absorber mounting bolts (1 & 2). Remove the shock bolts and remove the shock absorber from the bike. If there is not enough space to remove the shock absorber, also remove bolt (6) and the link (7).
- 6 Exchange the original spring for the HYPERPRO spring (see R1-R3)
- 7 Place the shock in the motorcycle. Place the top bolt (1). Mount all the parts in the correct order and lift the rear wheel up to place the final bolt (3 or 4). Tighten the nuts to the correct torque settings. If present, mount the remote reservoir and/ or remote preload adjuster .

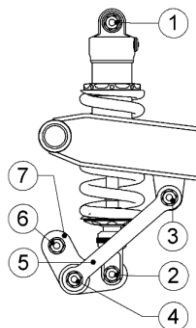

M3.1 - straight plates

M3.2 LINK SYSTEM – TRIANGULAR LINK PLATES

- 4 The easiest way is to remove the link plates. Make sure all parts can be refitted in the correct position. Usually it is enough to remove the shock bolt (2) and one of the link bolts (3 or 4) to remove the shock absorber. Remove more parts if more space is needed.
- 5 Remove the top nut and bolt (1) and take the shock absorber out of the bike. Depending on the bike this is possible along the upper side of the swing arm or underneath. Sometimes it is necessary to lift the rear wheel to create enough space to take the shock out.
- 6 Exchange the original spring for the HYPERPRO spring (see chapters R1-R3)
- 7 Place the shock in the motorcycle. Place the top bolt (1). Mount all the parts in the correct order and lift the rear wheel up to place the final linkage bolt. Tighten the nuts to the correct torque settings. If present, mount the remote reservoir and/ or remote preload adjuster.

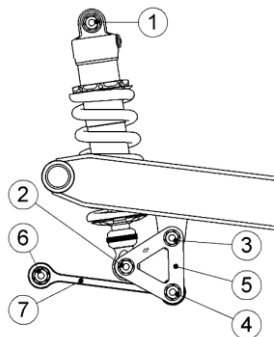

M3.2 - triangular plates

SHOCK SPRING CHANGE

R1. BASIC SHOCK

- 1 Remove the shock absorber from the bike (see M1-M3).
- 2 Remove the spring from the damper with a spring removal tool (G). Make sure only the spring and nothing else will be compressed. Set the plates against, but not over, the retaining ring on the spring. **WARNING!** Make sure the shock is placed stable, with no possibility of jumping out.

Compress the spring, if necessary push the bump rubber down with a small screwdriver and remove the retaining ring or clip.

Decompress the spring and remove the shock from the tool.

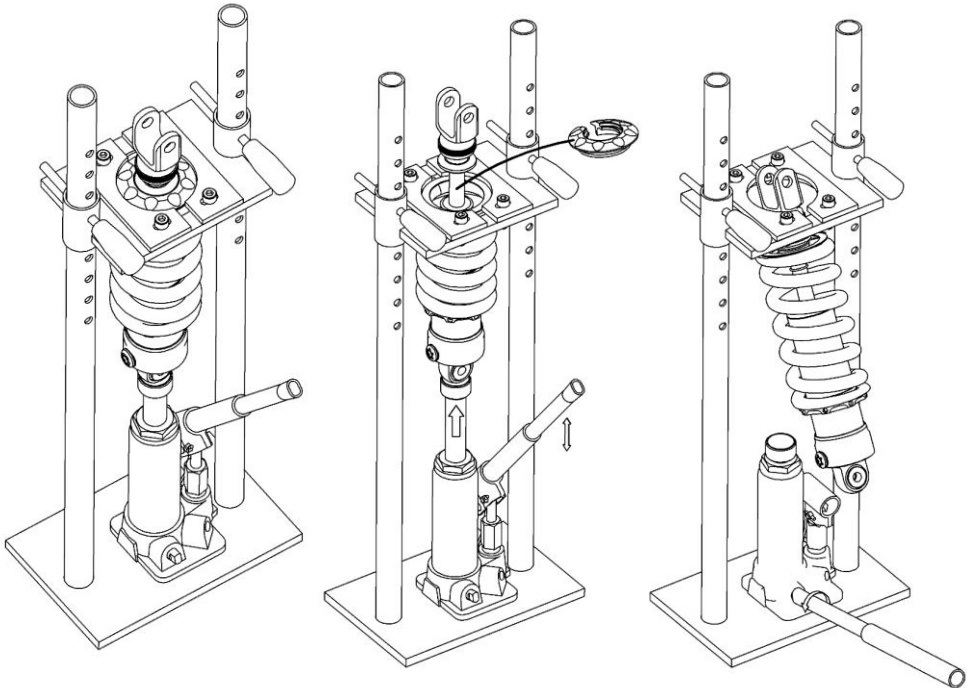

- 3 Check all the parts before reassembly. A leaking shock should be fixed.

Some shocks have an external reservoir. Never remove or open a reservoir; as this causes the damper to depressurize.

Note some shocks have a screw on the opposite side of the rebound screw on the fork. Removing this screw also depressurizes the damper.

4 Set the spring preload (see label: **SPRING PRELOAD**).

If the preload is set by a cam collar, the positions are always counted from the lowest preload setting (longest possible spring length on the shock) to the highest setting (i.e. the picture shows highest setting).

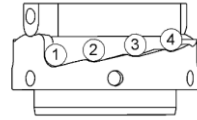

Sometimes there is a clip ring system that determines the base position of the spring retaining ring. The settings are counted from the lowest preload setting to the highest.

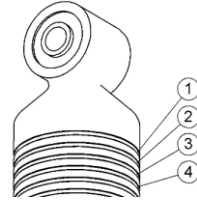

If the preload is set by threaded rings, first measure the free length of the HYPERPRO spring before mounting.

Screw the spring preload ring to the correct setting. Sometimes a locking screw has to be loosened before this can be done, else there are two rings.

The length of the spring mounted on the shock should be "free length" – "preload" (see label: **SPRING PRELOAD**)

Be sure to measure from the seating of the spring on the preload ring to the spring seating on the retaining clip(s). Pull the damper out; there is usually a rebound spring which affects the length.

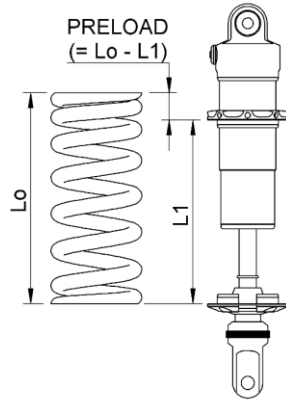

There are shocks (FJR/ TDM) with two main springs and two settings (soft & hard). Remove both springs and the adjustment mechanism. The adjustment mechanism will not be used anymore; the two springs are replaced by one progressive spring. The original spring seat with adjustment ring must remain on the shock (right picture) although the adjustment ring will not adjust the shock any more.



- 5 Mount the HYPERPRO spring on the damper. Usually the progressive side is mounted upwards (*) **unless there is a remark on the label**. Compress the spring and place the retaining ring on the shock. Decompress the spring.

Make sure the bolt holes are in line. Put a screwdriver through each hole of the shock to twist the holes in the correct position.

- 6 Measure the length of the spring again to be sure the preload is correct. The rebound spring could have affected the shock length measured at step 4. The preload can be adjusted with the spring fitted.

When the preload is correct, make sure the ring is locked in place, it must not move any more. The two rings are turned against each other or a locking screw is tightened.

- 7 Set the damping adjustment (if available) according to the settings as specified (see label: **REBOUND & COMPRESSION**)

The rebound (or tension, "TEN") screw (2) is usually located at the rod of the shock. Sometimes there is a ring which must be turned around the damper rod. The compression adjustment (3) is usually located at the external reservoir.

Turn the adjustment screws clockwise to the maximum. Turn the screws out (counter clockwise) the number of clicks or turns as specified on the label.

- 8 Mount the shock absorber on the bike (see M1-M3).

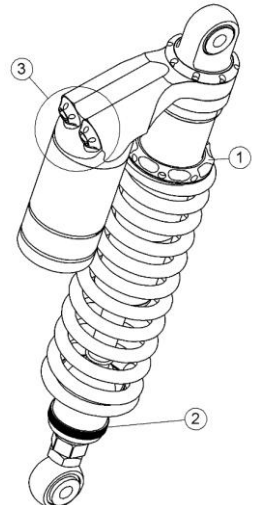
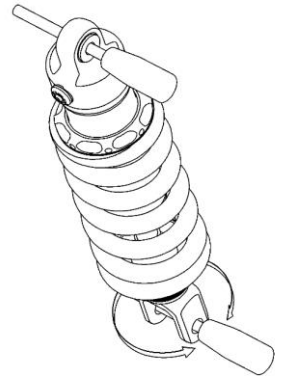
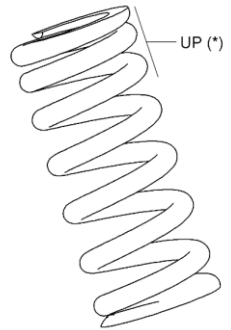

R2. SHOCK WITH HYDRAULIC PRELOAD ADJUSTER

- 1 Remove the shock absorber from the bike (see M1-M3).
- 2 Remove the spring from the damper with a spring removal tool. There are two possibilities for removing the spring (dependent on the shock):

Some shocks have a regular spring retaining ring at the rod side of the damper, see chapter R1.

Other shocks have a hydraulic preload adjuster which is held by a clip ring. Loosen the lock screw (7) on the preload adjuster. Use adapter ring (H) to be able to push on the preload unit. **WARNING!** Make sure the shock is placed stable, with no possibility of jumping out. **Note:** setting the preload to a minimum makes spring removal easier.

Compress the preload unit and spring until the clip ring appears. Remove the clip ring, then decompress the spring. Note the alignment for the screw (7) on the shock.

Don't adjust the preload when the spring is removed!

- 3 Check all the parts before reassembly. A leaking shock should be fixed.

Some shocks have an external reservoir. Never remove or open a reservoir, as this causes the damper to depressurize.

Note: some shocks have a screw on the opposite side of the rebound screw on the fork. Removing this screw also depressurizes the damper.

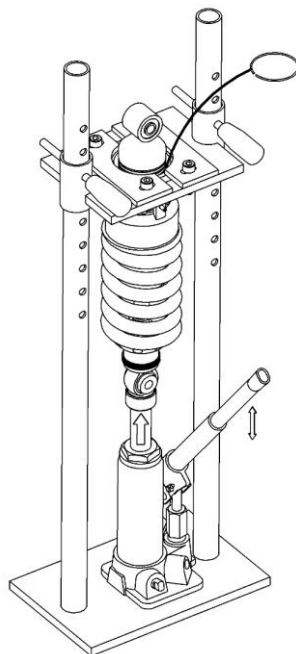
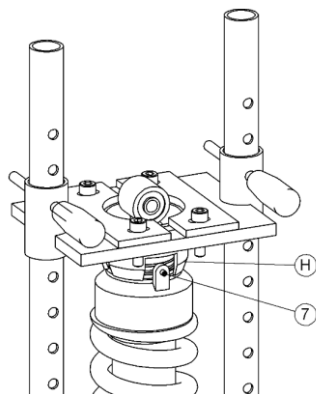

- 4 Mount the HYPERPRO spring on the damper. Usually the progressive side is mounted upwards (*) **unless there is a remark on the label**. Compress the spring and place the retaining ring on the shock. Decompress the spring.

Make sure the bolt holes are in line. Put a screwdriver through each hole of the shock to twist the holes in the correct position.

If the preload unit adjuster was removed, make sure the unit is in the original place and tighten the lock screw (7). The securing screw should align with the mark.

- 5 Set the preload adjustment to the correct setting. Turn the knob (1) until the specified value is reached (see label: **SPRING PRELOAD**).

- 6 Set the damping adjustment (if available) according to the settings as specified (see label: **REBOUND & COMPRESSION**)

The rebound (or tension, "TEN") screw (2) is usually located at the rod of the shock. Sometimes there is a ring which must be turned around the damper rod. The compression adjustment (3) is usually located at the external reservoir.

Turn the adjustment screws clockwise to the maximum. Turn the screws out (counter clockwise) the number of clicks or turns as specified on the label.

Some shocks have length adjustment (5). It is easier to modify the length when the shock is out of the bike.

- 7 Mount the shock on the bike (see M1-M3)

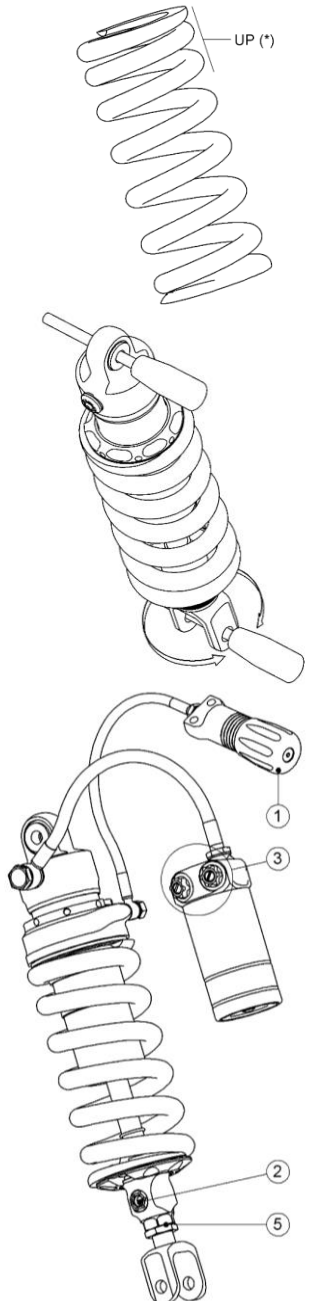

R3. PULL SHOCK

- 1 Remove the shock absorber from the bike (see M1-M3).
- 2 See picture A. Compress the spring using a spring removal tool (G). Compress until clip (10) is visible. Remove clip (10) from inside of the shell (3). Decompress the spring.
- 3 See picture B. Compress the spring, **be careful not to compress too far as this damages the shock**. Compress until clip ring (9) is visible. Remove clip (9) from the shock.
- 4 Unscrew the lock nut (7) while holding the preload ring (8). Remove the preload ring (8) and ring (4) followed by the spring. Note the mounting order of the parts.
- 5 Check the parts for their condition. A leaking shock should be fixed.

Some shocks have an external reservoir. Never remove or open a reservoir; as this causes the damper to depressurize. Removing the screw on the opposite side of the compression adjuster or removing the fork (6) will also depressurize the damper!

- 6 Fit the HYPERPRO spring in the shell. Place the spring retaining ring (4) on the spring. Compress the spring as picture B until the groove for the clip ring is visible on the shock body. Fit clip ring (9) on the damper. Decompress the spring.

Place the preload ring (8) on the damper.

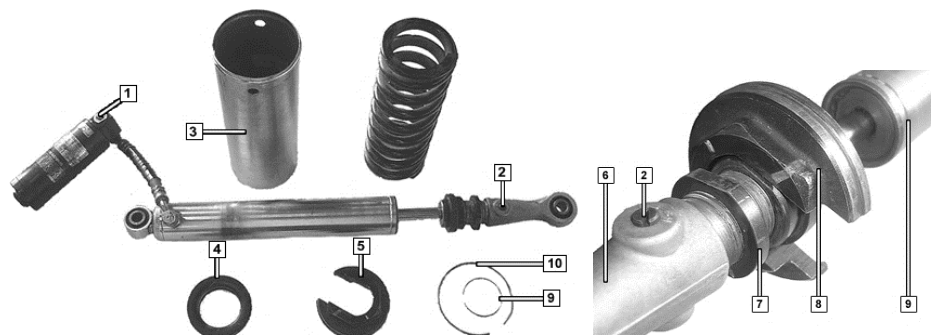
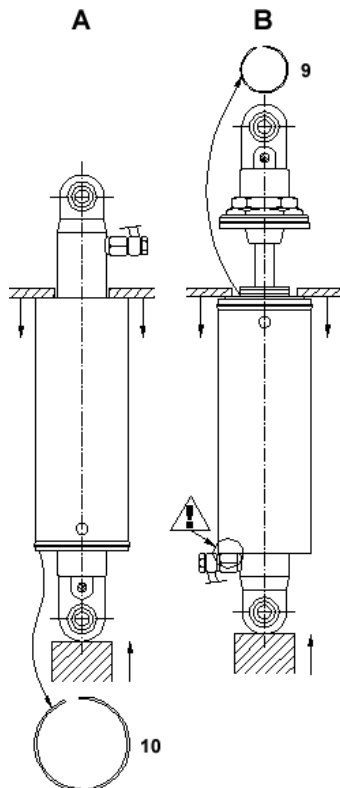

- 7 Measure the spring preload with the damper fully compressed. Adjust the preload to the setting as specified (see label: **PRELOAD**) Note: the preload adjustment for pull shocks is done opposite to normal shocks (picture)

Turn preload ring (8) until the specified preload setting is reached.

Hold the preload ring (8) in place and tighten nut (7) to lock it in place.

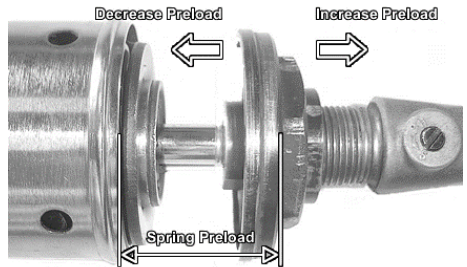

- 8 Compress the spring as picture A until ring (8) falls under the edge of the shell (3) Place clip ring (10) inside the groove in the shell. Decompress the spring.
- 9 Make sure the bolt holes are in line. Put a screwdriver through each hole of the shock to twist the holes in the correct position.
- 10 Set the damping settings as specified on the frontpage (see label: **REBOUND & COMPRESSION**)

On a pull shock, the rebound adjuster can usually be found at the external reservoir. The compression adjuster (2) is normally located at the bottom of the pull shock, on the fork (6)

Turn the adjustment screws clockwise to the maximum. Turn the screws out (counter clockwise) the number of clicks or turns as specified on the label.

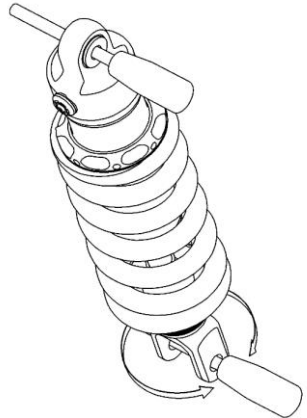

- 11 Mount the shock on the bike (see M1-M3)

R4. SHOCK MAINTENANCE

For proper maintenance of OEM shocks, please refer to the manufacturer's service manual.

In general, inspect the shock regularly for damage and leakage. Wash the shock with a mild detergent. Be careful with compressed air and avoid using aggressive cleaners. Protect your shock with WD40 or similar.

S1. SETUP, things to check first

Before there are any adjustments made to the suspension settings, be sure everything else is in a good working order using the following steps. Look up the details and settings in your motorcycle manual. Handling problems do not only occur when the suspension is set up wrong. Setting up the suspension is useless when the rest of the bike is bad!

- **Check the tires** - Wrong tire pressure can cause various handling problems, it should be checked regularly to insure good handling. The tire manufacturer can provide the correct information for your tires. Check the tires for any unusual wear, damage, leaks and correct thread depth. If the tires are worn out or otherwise bad, replace them.
- **Check the front suspension** - Place the bike stable with the front wheel off the ground. Make sure there is no weight resting on the front suspension. Grab the forks near the front axle. Try to push them front and back, there should be virtually no play between the steering head and the forks. Also notice if there is play in the forks, there should be very little play between the inner and outer tube. If there is play, it is likely the fork bushings are worn out; the fork should be rebuilt.
The steering stem can be tightened to set the play. Too tight and the steering becomes heavy. If there is play with a tight steering stem, check the steering head bearings as they are probably worn out, replace them if necessary. Steer the bike. If the movement is not smooth and/or notches are felt, the steering head bearings should be checked and if worn out they should be replaced.
Check the front suspension for leaking seals, replace them if necessary.
- **Check the rear suspension** - Place the bike stable with the rear wheel off the ground. Do not use a stand which supports the swing arm.
Try to move the swing arm from side to side. There should be little play between the swing arm and the rest of the bike. If there is play the swing arm bearings should be checked and if worn out they should be replaced.
Try to move the swing arm up and down. Feel for play between the swing arm, the frame and the shock bearings. If there is play, the bearings of the swing arm, link system and/ or the shock absorber are probably worn out.
- **Check the chain** - Make sure the chain slack is set correctly. Clean and lubricate the chain if necessary. The lubricant penetrates best when the chain is warm, just after riding the bike.
Tip: lubricate the chain after driving in the rain as the lubricant can be washed off by the rain. Make sure the wheel and sprockets are aligned properly. There are usually measurement stripes on the swing arm, for the alignment of the rear wheel when the chain free play is adjusted.
If any chain links are damaged, worn out, do not move smooth and/ or the sprockets are worn out, the chain and sprockets should be replaced.
- **Check the wheels** - Make the wheels spin. If a wheel doesn't move smooth or has a lot of drag, check if the brake is dragging. If a wheel has play in the mounting (the wheel can move sideways while the axle is tightened) the bearings are probably worn out; replace them if necessary. If there still are a lot of vibrations during riding, check the balancing of the wheels.
- **Check the wheel alignment** - if the wheels are not aligned properly the bike tends to steer to one side. This is also the case when the frame is not straight; if your bike has been in a crash it is possibly bent.

NOTE: If your bike is technically not in a good working order, visit a qualified dealer for service.

S2. STATIC SAG, measurement and adjustment

Static sag is the amount of stroke that is used as a result of the bike's own weight, without rider. It is best measured by two people; one measuring while the other is holding the bike upright.

S2.1 FRONT STATIC SAG MEASUREMENTS

Choose a distance to measure between the triple clamp and the wheel axle (e.g. visible chrome length). Measure the following situations:



S2.1 - sag measurements front

- A** Reference - Front wheel off the ground, no weight rests on the front suspension.
- B** Sag high - The bike is on both wheels, on a flat surface without rider. Pull up the front of the bike and let it come down on its own weight very slowly, don't push!
- C** Sag low - The bike stands up on both wheels, on a flat surface without rider. Push the front of the bike down and let it come up very slowly, slow down the movement so it does not bounce.

$$\text{Calculate Front Static Sag} = A - \left(\frac{B + C}{2} \right) = \dots \text{ mm}$$

Find the correct **STATIC SAG** on the label.

Front sag can be modified by changing the amount of fork spring preload, see S2.3.

(For road use the front sag without rider should be about 20% of the maximum fork stroke.)

S2.2 REAR STATIC SAG MEASUREMENTS

measure the length of the swing arm (L) Use a piece of tape to mark a point at the same distance (L) from the swing arm front bolt to the fairing. **NOTE:** Be sure to use tape that does not damage the fairing. Measure the distance from the rear axle to the point when:

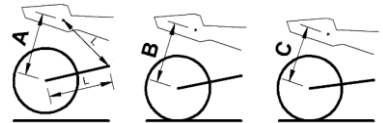

S2.2 - sag measurements rear

- A** Reference - The rear wheel is off the ground, no weight rests on the rear suspension.
- B** Sag high - The bike is on both wheels, on a flat surface without rider. Lift the rear end of the bike and let it come down under its own weight slowly, don't push!
- C** Sag low - The bike stands on both wheels, on a flat surface without rider. Push the rear of the bike down let it come up slowly, don't let it bounce!

$$\text{Calculate Rear Static Sag} = A - \left(\frac{B + C}{2} \right) = \dots \text{ mm}$$

Find the correct **STATIC SAG** on the label.

Rear sag can be modified by changing the amount of rear spring preload, see S2.3.

(For road use the rear sag without rider should be about 10% of the maximum rear wheel travel.)

NOTE: Sometimes preload and static sag are both mentioned on a label or in a service manual. The static sag is the most important value, if necessary adjust the preload until the desired sag value is reached.

S2.3 STATIC SAG ADJUSTMENT

Sag can be adjusted with the spring preload adjuster (if available). Adjust the preload in the correct direction and measure B and C again until the correct static sag is reached.

*For less sag, apply more spring preload.
For more sag, apply less spring preload.*

Front: Preload adjustment is easy if your fork is equipped with preload adjusters (1), usually less rings visible indicates more preload. (check the your vehicle's owner's manual for the exact location and function). Make sure both fork legs have the same preload setting.

Rear: See chapter R1-R3 on how to adjust the spring preload on your shock absorber.

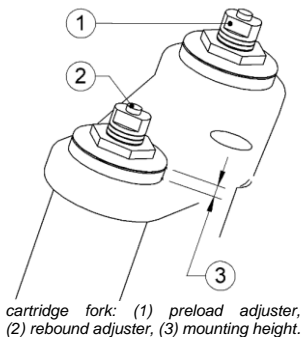

S2.4 SAG COMPENSATION FOR DUO OR EXTRA LOAD

Under heavy loads (i.e. with a passenger and luggage for a vacation) the sag increases. The bike is closer to the ground, there is less ground clearance. It is possible to apply more preload to compensate this.

Duo riding and/or luggage affect the shock more than the fork, as most weight is carried at the rear of the bike, so the preload increase for the shock should usually be larger.

Measure the rear static sag (see S2.2), without rider, but with the additional weight (passenger and/or luggage) on the bike. Increase the spring preload until the static sag is the same as the recommended **STATIC SAG** on the label.

Make sure you write down the preload adjustment (turns), so you can easily adjust back to the normal setting when necessary.

S3. DAMPING SETUP

The damping only adjusts the speed of the suspension movement, not the spring force.

The suspension will eventually move the same distance when the applied force is the same for long enough, independent of the damping. Damping settings only change the time it takes to get there. More damping slows the movement down and less damping makes it faster.

- **Rebound damping** controls the speed with which the suspension extends to the normal ride height after going over a bump or when releasing the brake. Rebound damping is also sometimes referred to as tension damping (“TEN”).
- **Compression damping** controls the speed with which the suspension is pushed together when hitting a bump or braking hard. Compression damping is also sometimes referred to as bump damping.

Rebound and compression damping settings can affect each other slightly in some forks and shocks. For example: a big increase in fork rebound damping can also give an increase in fork compression damping.

Left and right forks and shocks cannot affect each other obviously as the damping oil is separated, they should be setup equally. Some forks use separate function internals and will have only compression damping in one leg and only rebound damping in the other, check your vehicle’s owner’s manual for the available adjusters and their location on your bike.

First check the overall condition of the bike and make sure the static sag is adjusted properly before setting up the damping (see chapters S1 and S2).

To set the suspension up properly, test ride the bike every time something is changed.

If you change the suspension settings, the bike feels and handles different. Test ride the bike according to your normal riding conditions and riding style. Always ride safely and don’t take unnecessary risks! Avoid riding in heavy traffic because it can be dangerous when the bike handles different.

S3.1 BASIC DAMPING SETUP

- **Check the current setting and write it down.** Turn the damping screws to the maximum (clockwise) counting the number of clicks or turns while doing so. Clicks or turns are always counted from the maximum setting outwards (counter clockwise).
- **Use the base settings recommended by HYPERPRO.** They can be found on the labels (view: **REBOUND & COMPRESSION**). The HYPERPRO recommended settings are average settings for normal use. It is possible to adjust the suspension to your personal preference and driving style.
- Push the front and rear suspension and if it feels ok, **go for a test ride.**
If you are happy with the setup, you have finished the installation!
If you are not happy with the setup, you may proceed to the following chapters to find a better setting or, if you are not comfortable doing this yourself, consult a Hyperpro Service Dealer.

S3.2 ADVANCED DAMPING SETUP - FRONT

- **First, fully open the compression damping** (turn CCW until minimum is reached). This will allow you to push the fork without any restriction.
- **Increase the rebound damping until the suspension comes up with a smooth movement.** It should not move too fast (shoot up) and only bounce once; after pushing it should come up, top out, move back down to the static sag height and stop.
- **Increase the compression damping until it feels controlled, without being restrictive.** Use as little compression damping as possible. The major part of the suspension force should be absorbed by the spring, with the damping as a speed restriction. If the suspension compresses too fast increase the compression damping. Reduce the compression damping when the suspension compresses too slow, the bike feels harsh and bumps are directly passed through the frame to the rider.

Too much rebound damping makes the front feel locked up and harsh, feel of control is lost. Too much rebound damping can make the fork pack down; the bike does not return fast enough to the standard ride height after being compressed and gets lower and lower over a series of bumps. The front sits low and the bike tends to oversteer (drives towards the inside) in long fast corners and it sits up in slow corners. While accelerating, the front can tank slap because the front wheel loses traction.

Too little rebound damping makes the fork jump up when the brake is released. The suspension extends too fast when entering a corner, causing understeer in fast corners and falling down to the inside in slow corners. The front feels vague and gives little feedback.

Too much compression damping can make the fork compress too slow, resulting in slow steering into fast corners. Much compression damping can feel good during hard braking although the front feels very harsh over bumps, sometimes even kicking up. The front can shake and most bumps are felt directly through the handlebars.

Too little compression damping can make the fork dive much too fast during braking. The bike does not feel controlled when braking hard and over bumps. The bike oversteers (steers too fast) into corners. Under hard braking the rear wheel can lose traction.

S3.3 ADVANCED DAMPING SETUP - REAR

- **First, fully open the compression damping** (turn CCW until minimum is reached). This will allow you to push the rear without any restriction.
- **Increase the rebound damping until the suspension comes up with a smooth movement.** It should move as fast upwards as possible, without overshooting the static sag level. Push the rear, as the bike comes back up it should move with your hands, you shouldn't be able to lift your hands from the bike and the bike shouldn't be able to push your hands upwards.
- **Increase the compression damping until it feels controlled, without being restrictive.** Use as little compression damping as possible. The major part of the suspension force should be absorbed by the spring, with the damping as a speed restriction. If the suspension compresses too fast increase the compression damping. Reduce the compression damping when the suspension compresses too slow, the bike feels harsh and bumps are directly passed through the frame to the rider.

Too much rebound damping can make the rear pack down; the bike sits low at the rear and runs wide going out of long corners. The rear feels locked up and harsh. The bike sometimes kicks over bumps. The rear tire has bad traction, because the suspension doesn't allow the rear wheel to follow the road surface properly. The rear wheel bounces or hops uncomfortably over the ground during hard braking.

Too little rebound damping can make the bike wallow in a corner and over bumps. The rear can feel less controlled; it acts like a pogo stick. During hard braking the rear wheel has little traction and feels like it slides over the ground; it feels like the bike wants to pivot around the front. It's difficult to hold the bike in a straight line during braking.

Too much compression damping can make the rear feel very hard. The rear of the bike can kick up over bumps and most bumps are felt directly through the chassis. With too much compression damping the rear wheel can lose traction and slide while accelerating hard; the rear tire will overheat.

Too little compression damping can make the rear compress too fast when accelerating. The bike squats, causing understeer, the bike runs wide when accelerating hard out of fast corners. Sometimes the rear compresses so fast it results in tank slapping due to loss of traction at the front tire.

Sometimes there are separate **high speed and low speed damping** adjusters. High speed and low speed refer to the speed of suspension movement, not the road velocity of the motorcycle.

- **High speed damping** controls high speed suspension movements; i.e. hitting a big bump in the road. On a bump the suspension has to move very fast to absorb it. Don't use a lot of damping as this causes harshness, the wheel must be able to follow the road surface in order to maintain traction.
- **Low speed damping** controls low speed suspension movements; i.e. front compression during braking or rear compression during accelerating. Normally there is more low speed damping necessary than high speed damping. Low speed adjustments usually also affect the high speed adjustment; if the low speed damping is increased, the high speed damping is also increased.

The shape of the bump and the speed with which the bump is taken are the biggest influence for the speed with which the suspension must compress in order to make the tire follow the road surface. A sharp edged bump creates a higher suspension compressing speed than a rounded bump of the same height.

If the bike is harsh over bumps: decrease the high speed compression damping. If the bike dives too fast under braking: increase front low speed compression. If the rear squats too fast under acceleration: increase rear low speed compression.

Separate high and low speed damping adjusters are usually found on the compression only. Rebound can do with a single adjuster for the whole speed range, because the bike rebounds under the force of the spring; this is more consistent and independent of road conditions.

S3.4 ADVANCED DAMPING SETUP – FRONT AND REAR BALANCE

There must also be a balance between front and rear. Hold the bike when it is on both wheels. Push in the centre of the bike (seat or tank) and notice how it sags and comes back up.

Front and rear should compress and rebound at roughly the same rate. The suspension travel should be about the same distance front and rear.

The suspension can move a bit faster at the front, although the difference must not be too big as that would result in wallowing (weave/ wobble) and unstable handling behaviour through corners.

S3.5 DAMPING COMPENSATION FOR DUO OR RACING

For racing or duo riding there usually is some more damping needed than under normal conditions, in order to absorb the higher forces. Turn the adjustment screws a few clicks clockwise to increase the damping.

Duo riding and/or holiday luggage affect the shock more than the fork, as most weight is carried at the rear of the bike, so the damping increase for the shock should usually be larger. Racing affects the front as much as the rear.

Find an optimum setting that suits your riding style. Experiment by increasing or decreasing the damping to give the bike the desired handling behaviour. Use your own notes and experience to get a good feeling for the handling of your bike.

S4. HANDLING TROUBLESHOOTING CHART

First check the overall condition of the bike and make sure the static sag is set properly (S1 & S2).

Suspension parameter ► Handling problem ▼	Front preload	Front rebound	Front compression	Rear preload	Rear rebound	Rear compression	Ride height / geometry	Notes
<i>Long fast corners: Bike runs wide (understeered) Bike sits up</i>	-	+	-	+	-	+	lower front / raise rear	Front end rides high through the corner (multiple possible causes)
<i>Long fast corners: Bike runs narrow (oversteered) Bike falls in</i>	+	-	+	-	+	-	raise front / lower rear	Front end rides low through the corner (multiple possible causes)
<i>Short slow corners: Bike falls down to the inside (oversteered)</i>	-	+	-	+	-	+	lower front / raise rear	Front end rides high through the corner (multiple possible causes)
<i>Short slow corners: Bike sits up while turning (understeered)</i>	+	-	+	-	+	-	raise front / lower rear	Front end rides low through the corner (multiple possible causes)
<i>Front dives too fast when braking hard, doesn't bottom out</i>			+					Bike usually also oversteers in fast corners, steers into corners too easily (falls in)
<i>Front shoots up too fast after braking, turning into corners is difficult</i>		+						Bike usually also understeers in fast corners
<i>Rear squats fast under acceleration</i>				2nd +		1st +		Bike usually understeers when accelerating out of long corners
<i>Rear wheel loses road contact (traction) under hard braking</i>	3rd +		2nd +	4th -	1st +			It feels like the rear pivots around the front wheel, also a lot of dive during braking
<i>Tank slapping / front end shake at high speeds and fast acceleration (wobble)</i>		2nd -			3rd +	1st +	4th lower front / raise rear	Loss of front tire traction. A steering damper can reduce the unstable feel
<i>Wallowing / weave in mid corner (long, fast corners)</i>		2nd +	4th +		1th +	3rd +		A steering damper can reduce the unstable feel
<i>Over a series of bumps or ripples the bike packs down, there is no more travel to absorb bumps</i>		-			-			There is too much damping for the suspension to return fast enough to the normal ride height, ride is harsh
<i>Bike feels too harsh over bumps, suspension feels "locked up" over bumps, the bumps are felt directly through the frame</i>			-			-		Harshness is felt when the bike kicks up or skips over bumps. Locked up and harsh feel can also be caused by packing down!

+ increase, more / - decrease, less. The numbers reflect the likeliness of the solution (1st is most likely).

Ride height is adjusted with fork mounting height, shock length adjuster or link plate dimensions, but NOT with the spring preload.

This table only indicates the most common problems with the most likely solutions. Many handling problems are more complicated; please contact Hyperpro if your problem cannot be solved with this manual.

SETTING LABEL

WARNING! – Installing a suspension component that is not correct for your bike can affect the stability of your bike. Hyperpro cannot be held responsible for any form of damage to any component, motorcycle or personal injury when there is improper installation of the component and/or if the instructions for mounting or maintenance are not followed exactly. Similarly, the warranty will become void if the instructions are not followed.

ABE documents may be available in the downloads section of our website:

This document may be available for download in other languages, please see our website:

WWW.HYPERPRO.COM

Hyperpro Suspension Technology, Hulsenboschstraat 26, 4251LR, Werkendam, The Netherlands

+31(0)183-678867, info@hyperpro.com